

# TQP200002

## ESD Protection Device



### Applications

- Cellular Handsets
- Cordless Phone
- LNBS
- CATV set top boxes

### Product Features

- Snap-Back ESD protection
- Low clamp voltages 15 or 30 V
- Low trigger voltages 18, 25, or 41 V
- Two bidirectional protection lines
- Fast response time, under 1 ns.
- ESD Protection: IEC 61000-4-2, level 1  
JEDEC HBM, 8 kV
- Low capacitance 0.22 pF
- Thin Small Leadless SMT Package ( $A = 1.8 \text{ mm}^2$ )

### General Description

The TQP200002 ESD protection device is fabricated in GaAs MESFET technology and has been especially developed for high frequency applications. It delivers bi-directional protection with very low leakage currents and extremely low capacitance. It is ideally suited for cellular handsets, cordless phones, and broadband applications like CATV set top boxes and LNBS.

#### Snap-Back Characteristics:

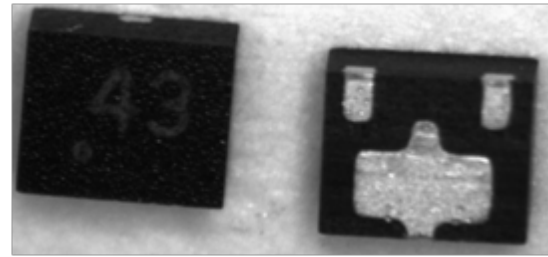
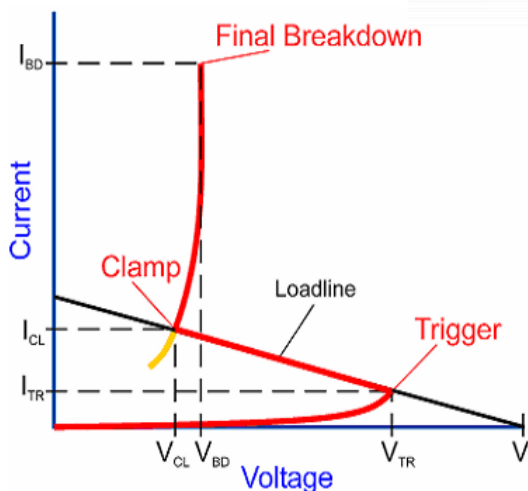

### Functional Block Diagram

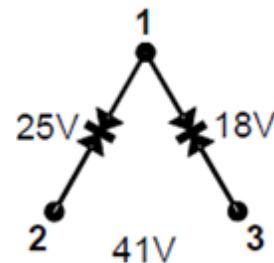

### Pin Configuration

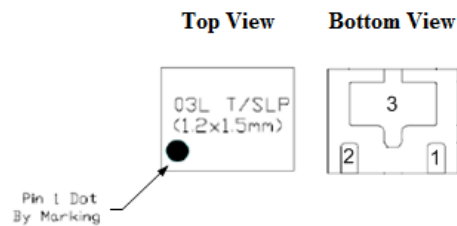

Symbol	Function
V1	Measured between pin 1 and pin 3.
V2	Measured between pin 1 and pin 2.
V3	Measured between pin 2 and pin 3.

### Ordering Information

Part No.	Description
TQP200002	ESD Protector Diode
TQP200002-PCB-75	75 Ohm Evaluation Board
TQP200002-PCB-50	50 Ohm Evaluation Board

Standard T/R size = 10,000 pieces on a 13" reel.

### Specifications

#### Absolute Maximum Ratings

Parameter	Rating
Storage Temperature	-65 to +150 °C
Total Power Dissipation	600 mW
IEC 61000-4-2 Air Discharge	3000 V
IEC 61000-4-2 Contact Discharge	3000 V
JEDEC Human Body Model (HBM)	8000 V

Operation of this device outside the parameter ranges given above may cause permanent damage.

#### Recommended Operating Conditions

Parameter	Min	Typ	Max	Units
$V_{d13}$	-7	--	7	V
$V_{d12}$	-7	--	7	V
$V_{d23}$	-17	--	17	V
$T_{case}$	-40		85	°C
$T_J$ (for >10 <sup>6</sup> hours MTF)			160	°C

Electrical specifications are measured at specified test conditions. Specifications are not guaranteed over all recommended operating conditions.

#### Electrical Specifications

Test conditions unless otherwise noted: 25°C

Parameter	Conditions	Min	Typical	Max	Units
Trigger Voltage, $V_1$	P1,3	13	18	23	V
Clamp Voltage, $V_{cl1}$	P1,3	10	15	20	V
Leakage Current, $I_{leak1}$	1 V		20		nA
Leakage Current, $I_{leak1}$	15 V		500		nA
Capacitance, $C_1$	(1V, 10 MHz)		290		fF
Trigger Voltage, $V_2$	P1,2	20	25	30	V
Clamp Voltage, $V_{cl2}$	P1,2	10	15	20	V
Leakage Current, $I_{leak2}$	1 V		20		nA
Leakage Current, $I_{leak2}$	15 V		500		nA
Capacitance, $C_2$	(1V, 10 MHz)		290		fF
Trigger Voltage, $V_3$	P2,3	36	41	46	V
Clamp Voltage, $V_{cl3}$	P2,3	20	30	40	V
Leakage Current, $I_{leak3}$	1 V		15		nA
Leakage Current, $I_{leak3}$	15 V		300		nA
Capacitance, $C_3$	(1V, 10 MHz)		220		fF

**Device Characterization Data**

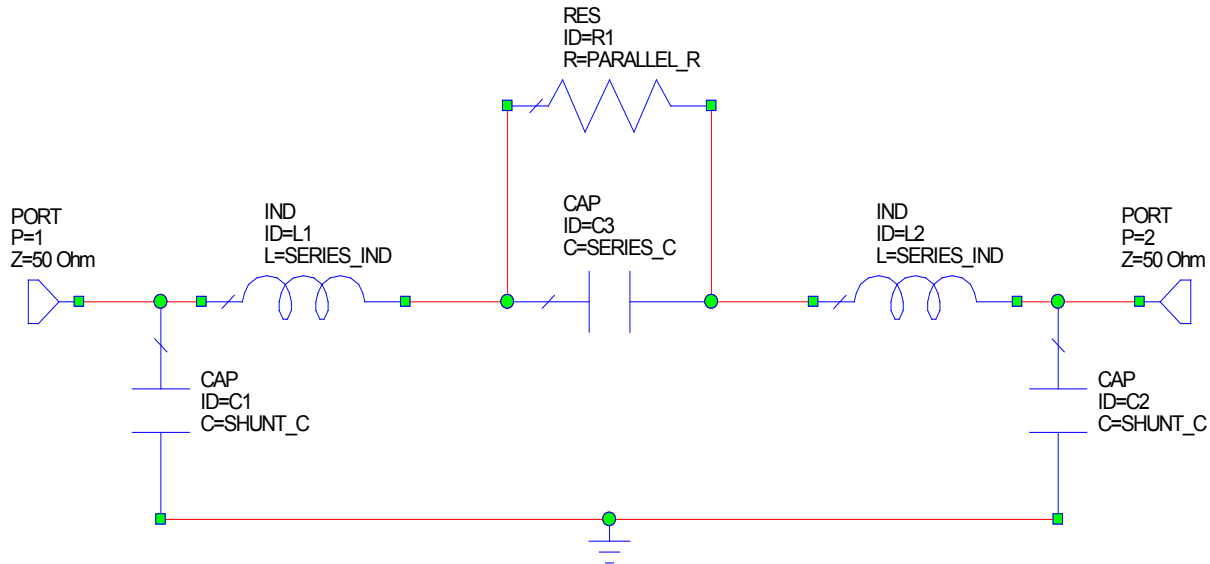

**Small Signal Model: Pin 2 to Pin 3**

Pin 2 to Pin 3 Small Signal Element	Value	Unit
SERIES_C	0.22	pF
SHUNT_C_IN**	0.08	pF
SHUNT_C_OUT**	0.01	pF
SERIES_IND	0.2	nH
PARALLEL_R	230	MΩ

\*\*Note: Values of input and output shunt capacitances are dependent upon board material and the board pad sizes, and will be layout dependent

### Typical Performance 50-1200 MHz

Trigger Voltage		V1 = 18V	V2 = 25V	V3 = 41V
Insertion Loss	dB	0.3	0.25	0.25
Input Return Loss	dB	19	21	21
Output Return Loss	dB	19	21	21

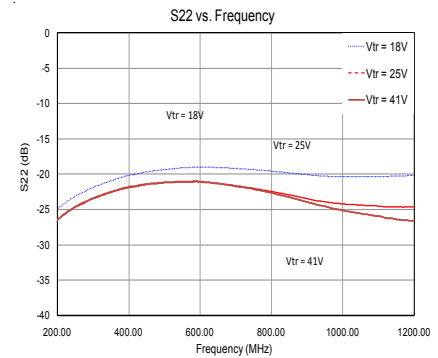
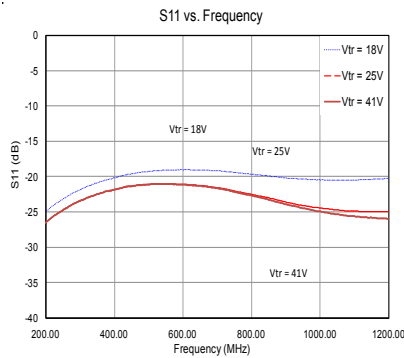
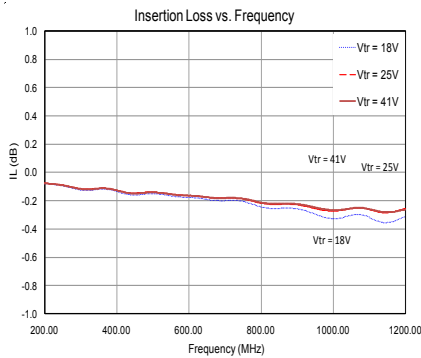

### Distortion Performance: ACPR

Test conditions: ACPR data was taken against a baseline obtained for the TAT8857 at 990 MHz.  
 Channel plan: 4 combined channels, 256 QAM modulation per Docsis 3.0.

ACPR3 vs. Pout, Fr = 990 MHz

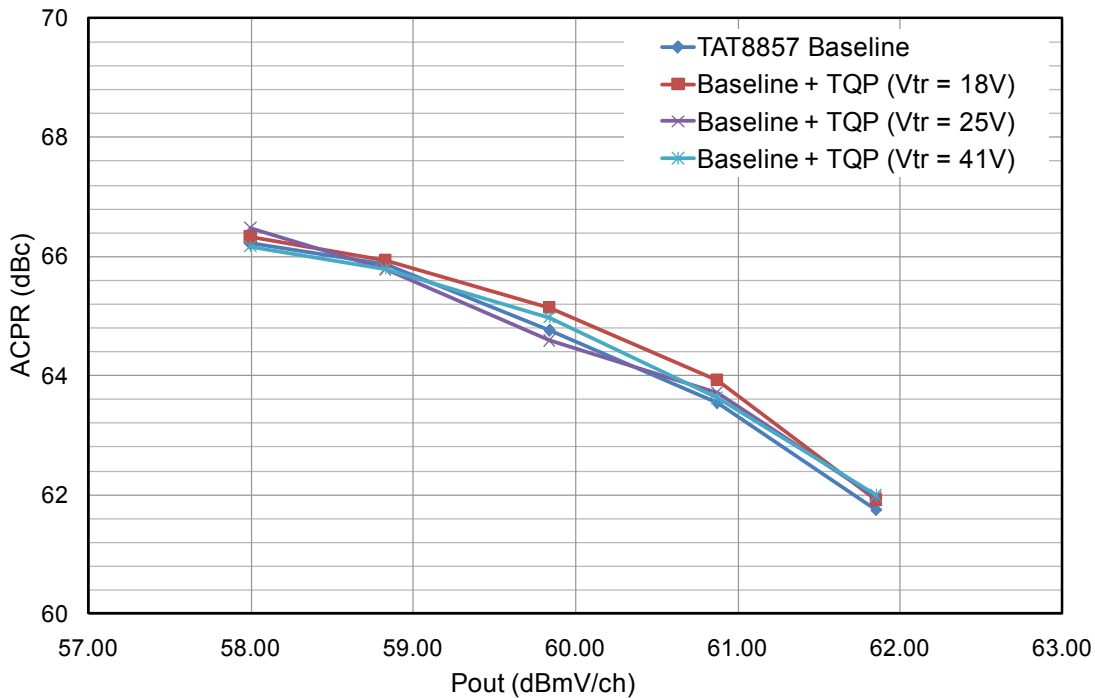

Note: ACPR3 – 6 MHz from channel block edge, to 12 MHz from channel block edge.

### Distortion Performance: CTB/CSO

Test conditions: Distortion data was taken against baselines obtained for the TAT8857 and an industry leading GAN module.

Channel plan: 79 ch. NTSC + QAM to 1 GHz, with 13 dB tilt at input.

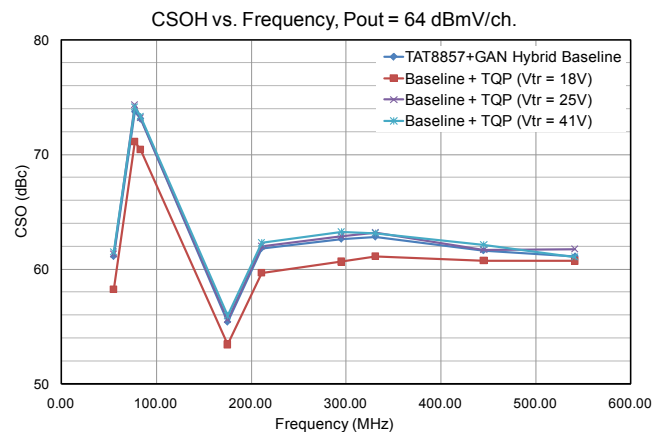
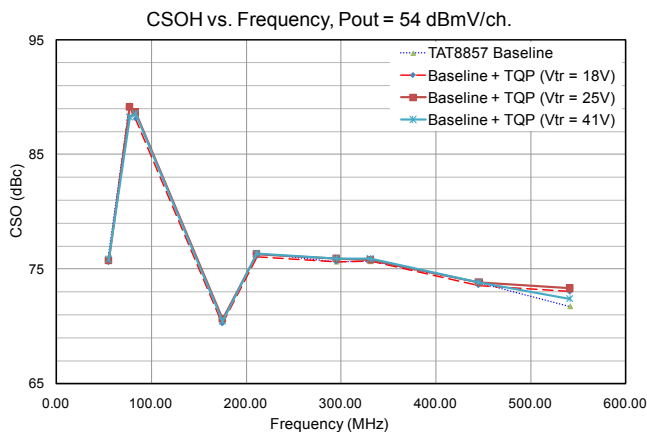
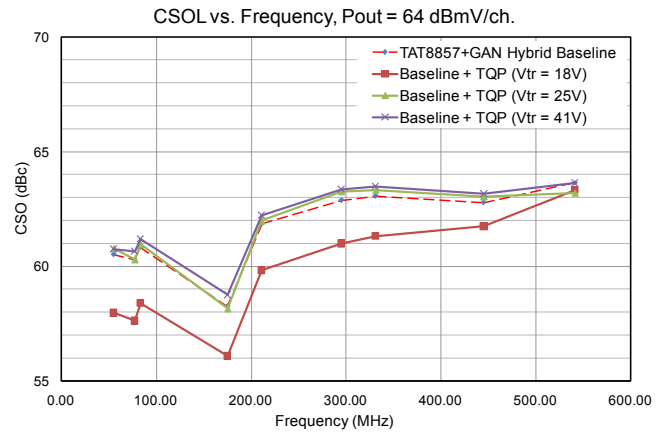
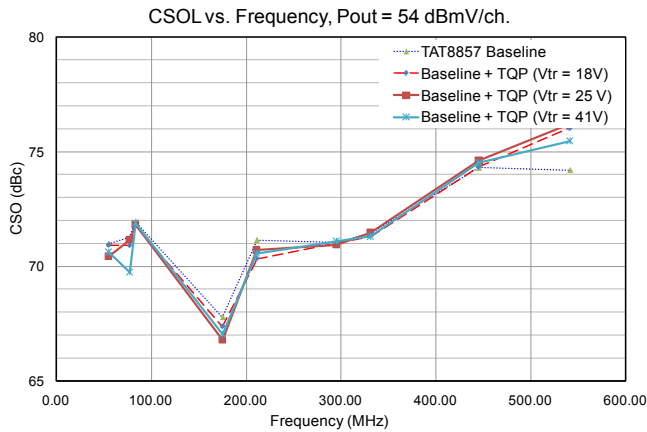
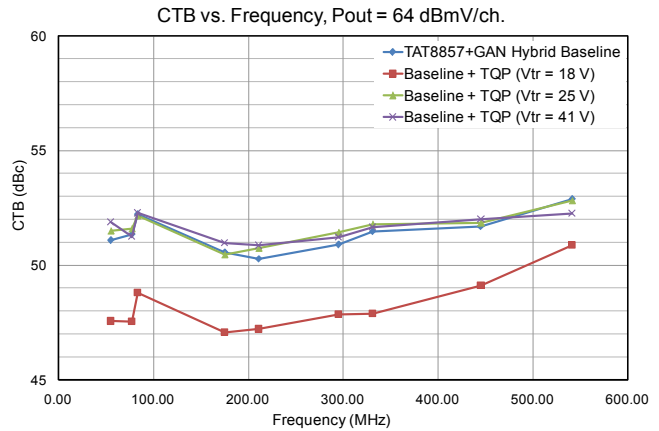
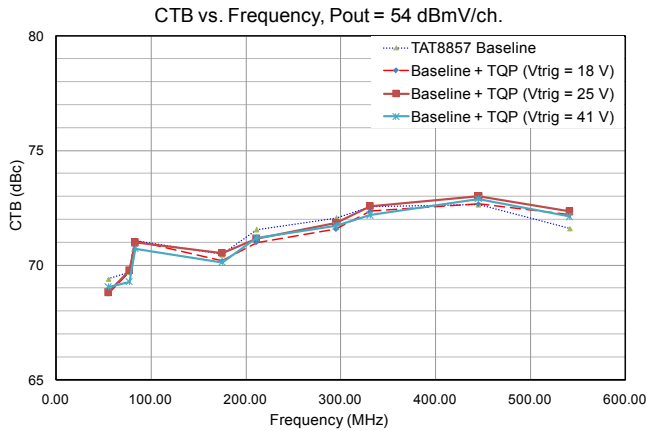

### Applications Information

#### Evaluation Board Layout

The TQP200002 75 ohm evaluation board features a 2 layer coplanar design using FR4,  $\epsilon_r = 3.7$ , with an overall board thickness of 0.028". Metal layer is 1-oz copper. Microstrip line details: width = .023", spacing = .032".

For further technical information, Refer to [www.TriQuint.com](http://www.TriQuint.com)

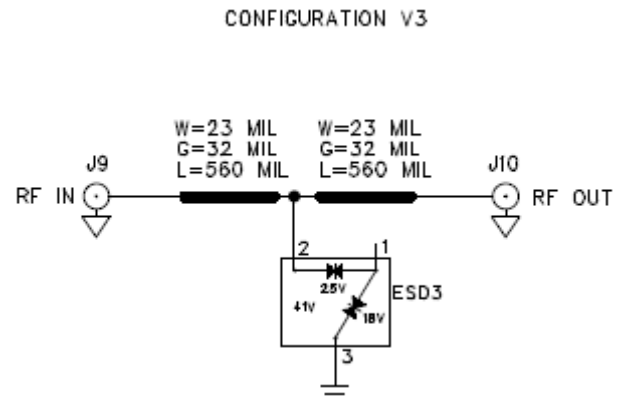
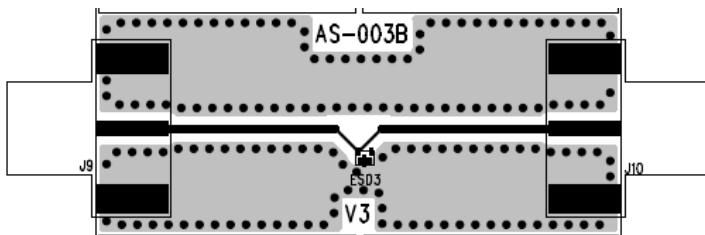
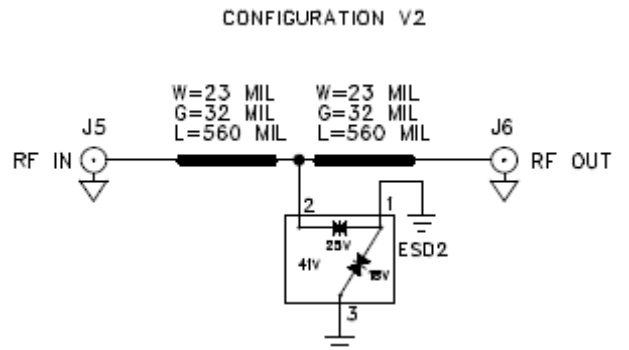
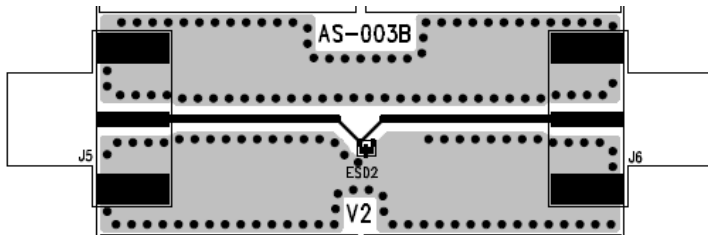
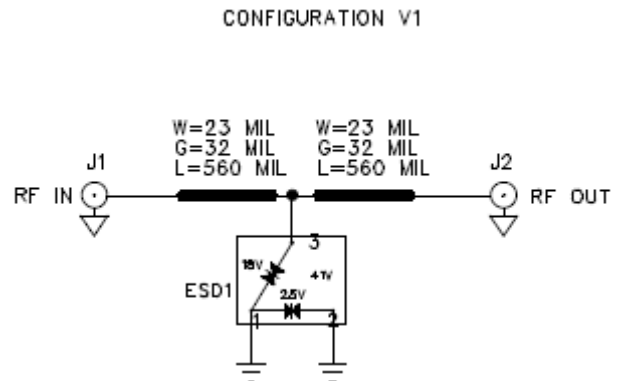
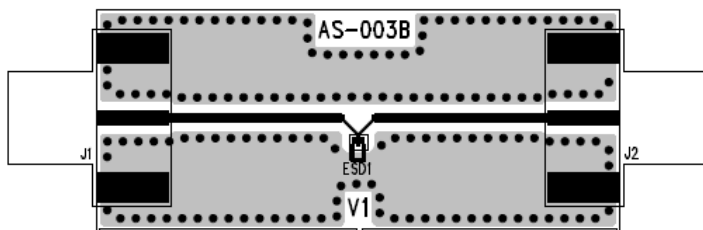

## Mechanical Information

### Package Information and Dimensions

The TQP200002 package is lead-free/RoHS-compliant.

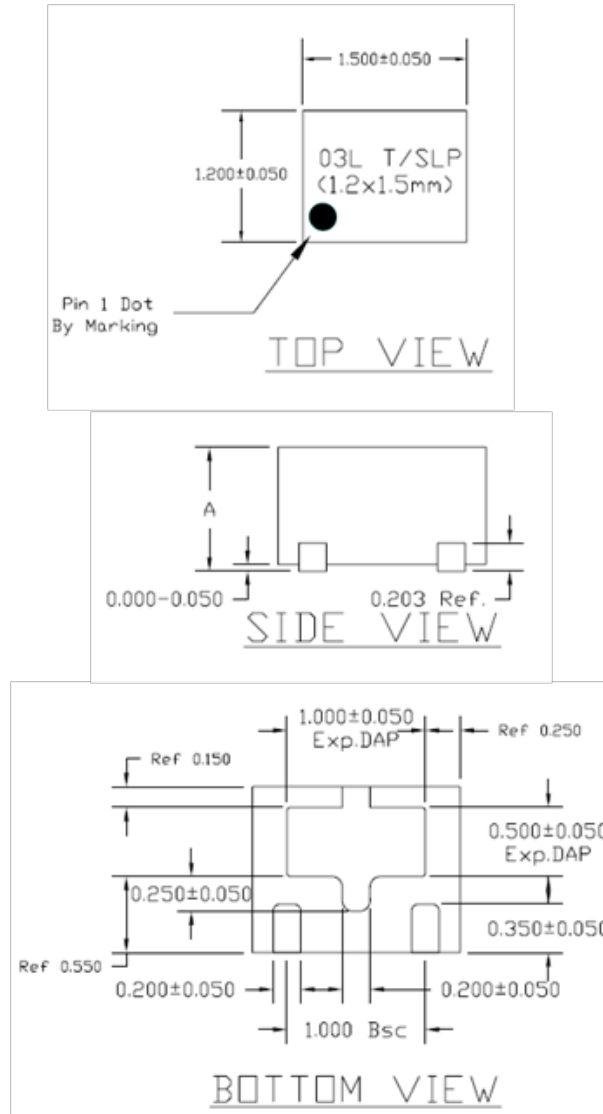

### Tape and Reel Information

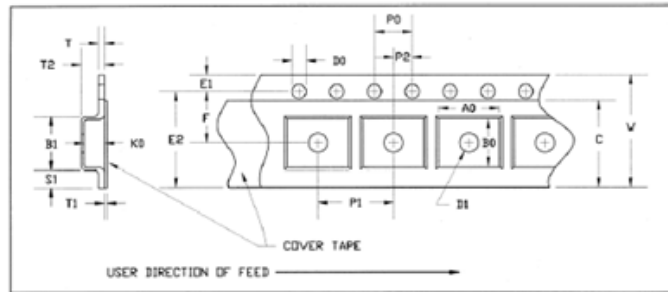
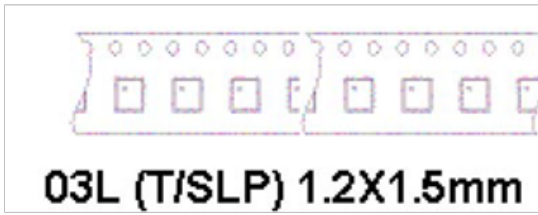

### T/SLP 1.2x1.5 mm WIDE CARRIER AND COVER TAPE DIMENSIONS

Part	Feature	Symbol	Size (in)	Size (mm)
Cavity	Length	A0	0.053	1.35
	Width	B0	0.068	1.75
	Depth	K0	0.040	1.02
	Pitch	P1	0.157	4.00
Distance Between Centerline	Cavity to Perforation Length Direction	P2	0.079	2.00
	Cavity to Perforation Width Direction	F	0.138	3.50
Cover Tape	Width	C	0.213	5.40
Carrier Tape	Width	W	0.315	8.00

### Reel Dimensions:

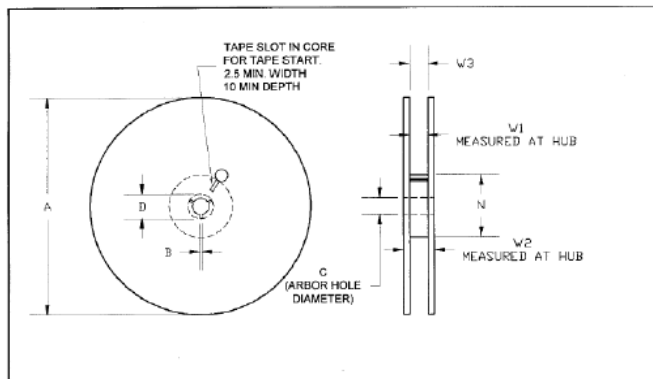

Reel Dimensions for 8mm Carrier Tape – 13" Reel (Blue)

T/SLP	FEATURE	SYMBOL	13" REEL	
PART			SIZE (in)	SIZE (mm)
FLANGE	DIAMETER	A	12.992	330.0
	THICKNESS	W2	0.567	14.4
	SPACE BETWEEN FLANGE	W1	0.331	8.4
HUB	OUTER DIAMETER	N	3.937	100.0
	ARBOR HOLE DIAMETER	C	0.512	13.0
	KEY SLIT WIDTH	B	0.059	1.5
	KEY SLIT DIAMETER	D	0.795	20.2



### Product Label and Marking

#### Part Marking:



WHITE INK OR LASER MARK  
 Line 1: XX = Last 2 digits of TriQuint assembly lot number

#### Triquint Standard Customer Label (No CPN)

NO.	DESIGNATION	Data Identifier	SHORT NAME	LENGTH	REMARK
1	Manufacturer		TriQuint Semiconductor	NA	Name of Firm.
2	Manufacturer Part Number		MPN	18	
3	Supplier Code	V	Scode	10	Vendor Code.
4	Lot Number	1T	MLOT	13	Lot/Batch Number. 3 lot Maximum.
5	TriQuint Catalog Number	1P	TCN	40	
6	Country Code		CC	3	Country of Origin
7	PB Free Logo				Lead Free Marking
8	Date Code	9D	DCODE	4	Format: "YYWW"
9	Quantity	Q	QTY	9	

#### Carton Label

**Format 4 \* 2 in. 102 \* 51 mm Code 39, 1:2**

**Ship From:** TRIQUINT SEMICONDUCTOR, INC. 1000 NE BROOKWOOD PARKWAY HILLSBORO, OR 97124

**Ship To:**

**(3S) Pkg ID: 581 + 23099631**

**(K) Trans ID:**

**(P) CPN:**

**(Q) QTY: 5000**

**(1P) SPN: CGB 241 E6327** MPN: 1022084

**(13Q) Pkg Count: 1/1**

**Package Weight**  
1.9 LB / 0.84 KG

**Lead Free Logo**

*All Barcodes Contain Data Identifier Followed by Data, e.g. K812934657*

### Product Compliance Information

#### ESD Information



**Caution! ESD-Sensitive Device**

ESD Rating: Class 3B  
Value: Passes  $\geq 8$  kV min.  
Test: Human Body Model (HBM)  
Standard: JEDEC Standard JESD22-A114

#### MSL Rating

Level 1 at +260 °C convection reflow  
The part is rated Moisture Sensitivity Level 1 at 260°C per JEDEC standard IPC/JEDEC J-STD-020.

#### Solderability

Compatible with the latest version of J-STD-020, Lead free solder, 260°

This part is compliant with EU 2002/95/EC RoHS directive (Restrictions on the Use of Certain Hazardous Substances in Electrical and Electronic Equipment).

This product also has the following attributes:

- Lead Free
- Halogen Free (Chlorine, Bromine)
- Antimony Free
- TBBP-A (C<sub>15</sub>H<sub>12</sub>Br<sub>4</sub>O<sub>2</sub>) Free
- PFOS Free
- SVHC Free

### Contact Information

For the latest specifications, additional product information, worldwide sales and distribution locations, and information about TriQuint:

**Web:** [www.triquint.com](http://www.triquint.com)  
**Email:** [info-sales@tqs.com](mailto:info-sales@tqs.com)

**Tel:** +1.503.615.9000  
**Fax:** +1.503.615.8902

For technical questions and application information:

**Email:** [applications.engineering@tqs.com](mailto:applications.engineering@tqs.com)

### Important Notice

The information contained herein is believed to be reliable. TriQuint makes no warranties regarding the information contained herein. TriQuint assumes no responsibility or liability whatsoever for any of the information contained herein. TriQuint assumes no responsibility or liability whatsoever for the use of the information contained herein. The information contained herein is provided "AS IS, WHERE IS" and with all faults, and the entire risk associated with such information is entirely with the user. All information contained herein is subject to change without notice. Customers should obtain and verify the latest relevant information before placing orders for TriQuint products. The information contained herein or any use of such information does not grant, explicitly or implicitly, to any party any patent rights, licenses, or any other intellectual property rights, whether with regard to such information itself or anything described by such information.

TriQuint products are not warranted or authorized for use as critical components in medical, life-saving, or life-sustaining applications, or other applications where a failure would reasonably be expected to cause severe personal injury or death.